

COMMERCIAL
STAINLESS STEEL

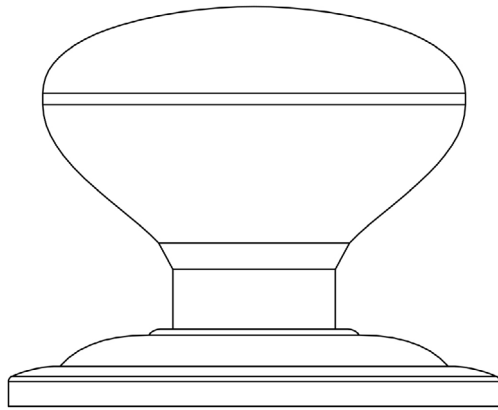

CODE

JSS3580

DESCRIPTION

Centre Door Knob

STANDARDS



PRODUCT SPECIFICATION

- Grade 5 corrosion
- *We strongly recommend requesting a sample before committing to any cutting or drilling*

TECHNICAL DRAWING

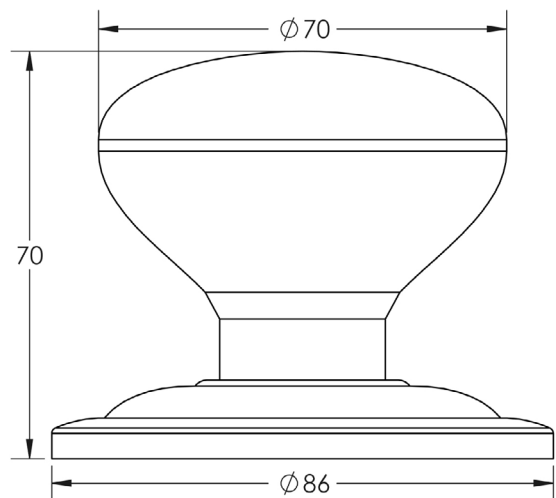

FINISHES

- Satin Stainless Steel