



CODE

JS101

DESCRIPTION

Fire Door Keep Locked Sign

STANDARDS



PRODUCT SPECIFICATION

- Corrosion grade 4
- *We strongly recommend requesting a sample before committing to any cutting or drilling*

TECHNICAL DRAWING

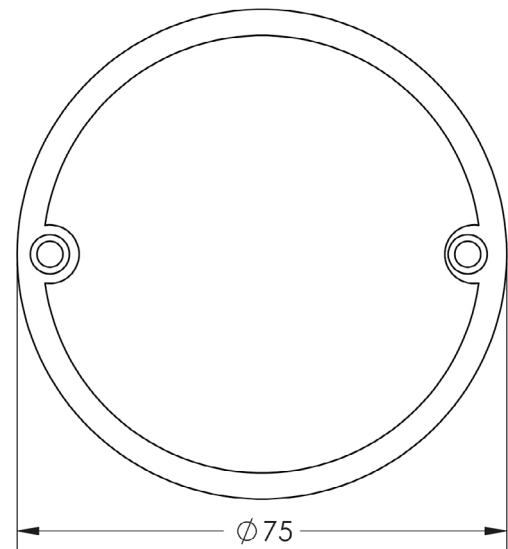

FINISHES

- Matt Black
- Polished Brass
- Polished Stainless Steel
- Satin Stainless Steel