

### CODE

JL-DL60R

### DESCRIPTION

Din Lock - Radius Plate

### STANDARDS



### PRODUCT SPECIFICATION

- Sprung
- Grade 4 corrosion
- Available in square plate
- Grip tight follower spring
- BS EN 12209:2003
- *We strongly recommend requesting a sample before committing to any cutting or drilling*

### TECHNICAL DRAWING

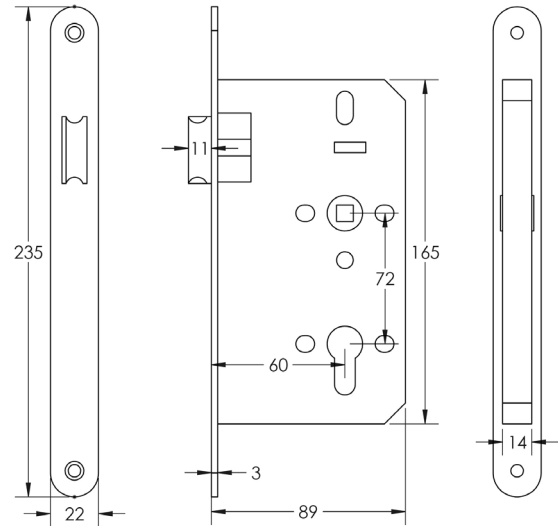

### CLASSIFICATIONS

Category Of Use	Durability	Door Mass	Fire Resistance	Safety	Corrosion Resistance	Security	Field Of Door	Type Of Key	Type Of Spindle	Key Identification
3	X	8	1	0	G	-	B	O	2	0

### FINISHES

- Antique Brass
- Dark Bronze
- Matt Black
- Satin Brass
- Stainless Steel