

CODE

JL-DE60

DESCRIPTION

Escape Lock - Square Plate

STANDARDS



PRODUCT SPECIFICATION

- Sprung
- Suitable door thickness: 35-54mm
- Grade 3 corrosion
- Available in radius plate
- Grip tight follower spring
- *We strongly recommend requesting a sample before committing to any cutting or drilling*

TECHNICAL DRAWING

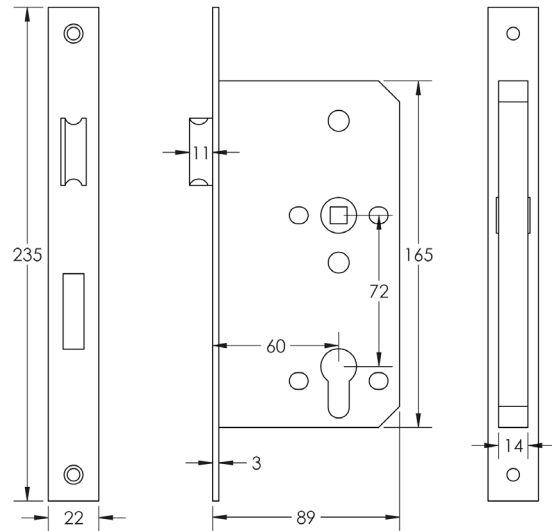

CLASSIFICATIONS

Category Of Use	Durability	Door Mass	Fire Resistance	Safety	Corrosion Resistance	Security	Field Of Door	Type Of Key	Projection Of Device
3	7	6	B	1	3	4	D/B	A	2

FINISHES

- Antique Brass
- Dark Bronze
- Matt Black
- Satin Brass
- Stainless Steel