

CODE

BUR20KIT168

DESCRIPTION

Lever On Plate

STANDARDS



PRODUCT SPECIFICATION

- 38mm centres
- Sprung
- Din euro lock plate
- Grade 4 corrosion
- Matt lacquered solid brass
- Back to back fixing recommended
- Suitable for doors 35-55mm

TECHNICAL DRAWING

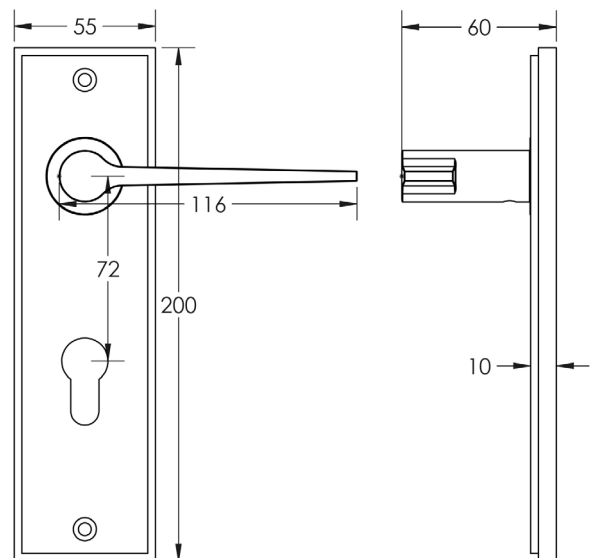

FINISHES

- Polished Nickel

